

Mastering Complex WIRING DIAGRAMS

Complicated wiring schematics offer a wealth of information but can be awfully difficult to decipher. Dividing them into smaller, more manageable bits can make your job go a heck of a lot smoother. Here's how to go about it.

BY JORGE MENCHU

When you're engaged in a tough diagnostic battle, the last thing you want to do is fight the reference material needed to fix the car! So it's vitally important for you to become familiar with this material, what it offers and the terminology it uses.

One of the most important offerings of any automotive information library is the wiring diagram. Many experienced technicians use this little nugget of information as their main diagnostic guide, because they know it offers so much more than simply locating grounds and pin-outs. Inside a wiring diagram you can often see the relationships of circuits to one another, what type of test to perform, what types of signals to expect and sometimes how a

particular system is designed to work.

To get the most out of wiring diagrams, you must have a decent understanding of electronics and the basic strategies on which circuits and automotive systems are based. I cannot stress enough the value of understanding electricity and circuit components. After all, this is the foundation of all automotive control systems.

When working with or learning about wiring diagrams, the approach you take is very important. As with anything complex, diagrams are easier to deal with in manageable bits. Since there are many aspects to wiring diagrams, there are many approaches. Regardless of what approach you take, keep the following key concepts in mind:

- Complex wiring diagrams are made up of many individual circuits. Some are

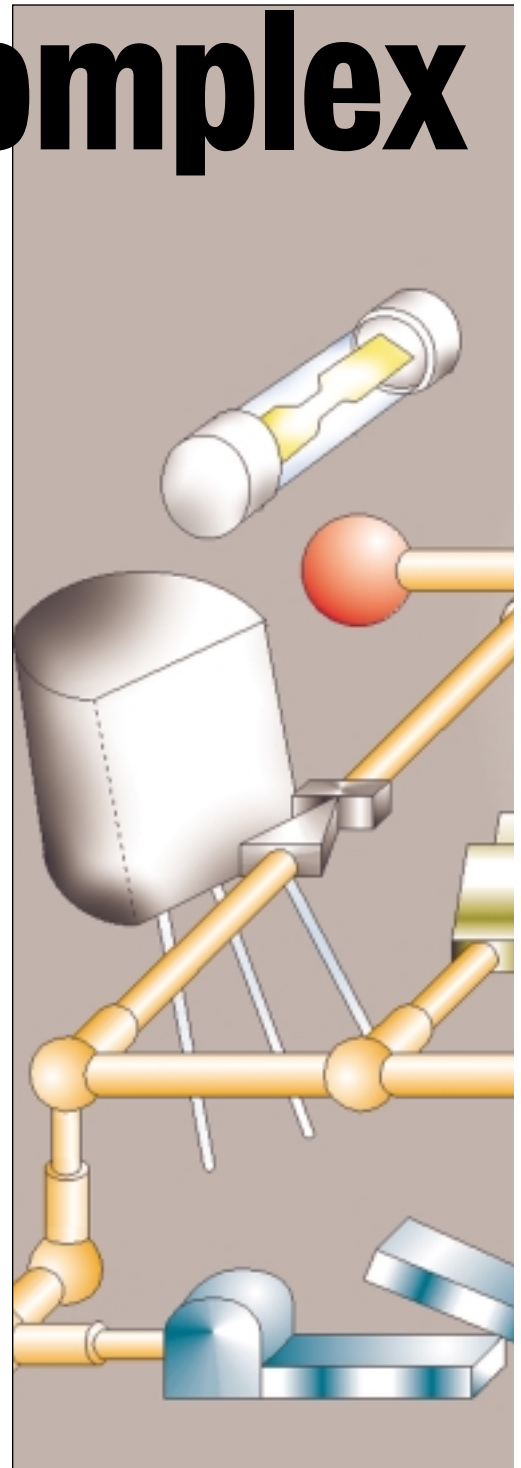

directly interrelated and others are not.

- There will always be a power side and a ground side for every load.
- In every circuit there is a load.
- There are five basic voltage conditions.

Most of these concepts are fairly

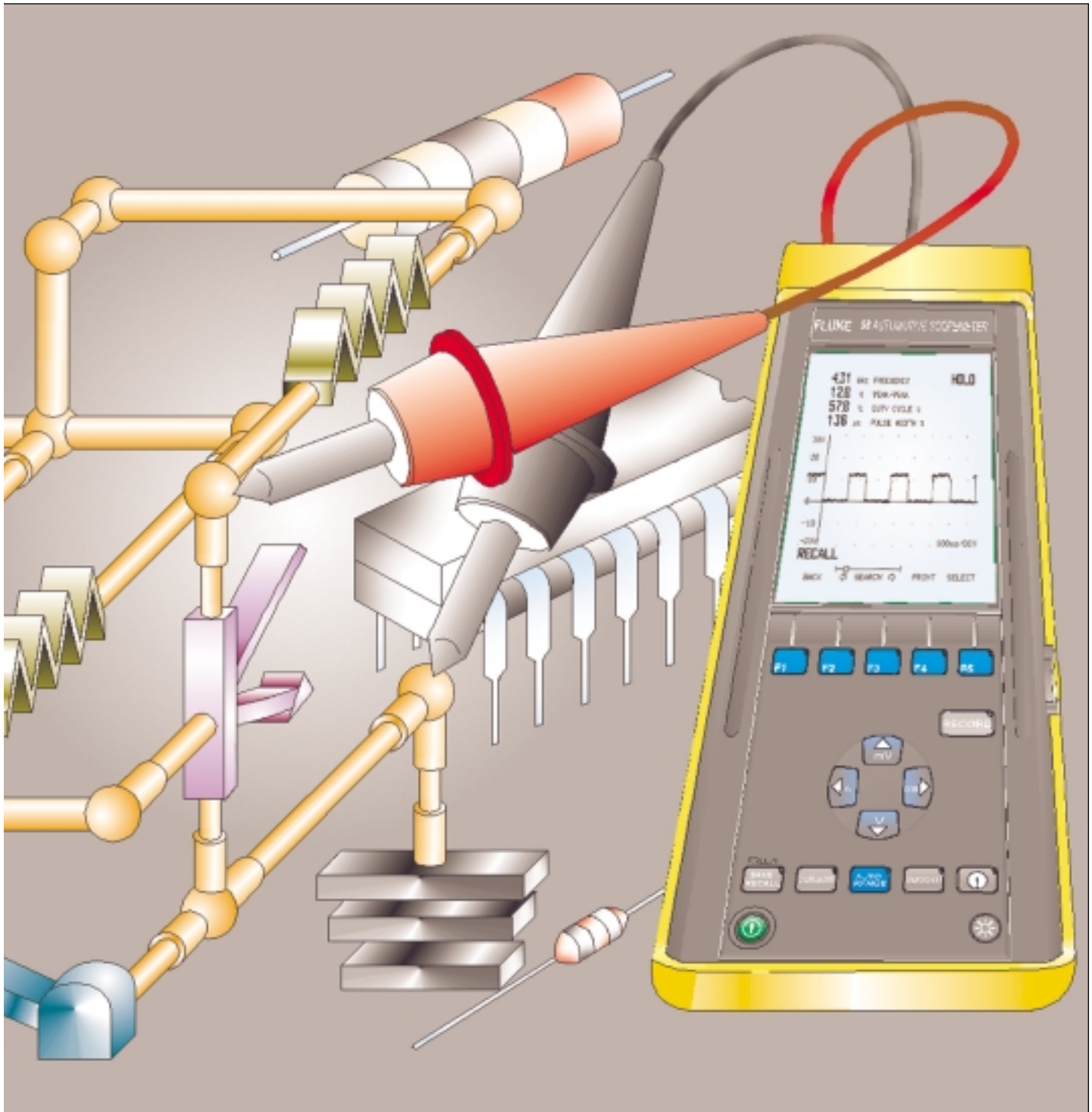

Schematics: Jorge Menchu

straightforward. The word *load* refers to the device that performs the work in a circuit. In Fig. 1 (shown on page 33), the load is represented by a resistor symbol. Contrary to what some may think, the switch is not the load!

The legend in Fig. 1 shows the five

basic conditions that represent voltage levels found in a circuit as read by a high-impedance voltmeter. These conditions are the result of the arrangement and state of the circuit. It's important to understand the differences among them, since the principles they

illustrate are key for proper diagnosis.

Power (red) refers to that part of the circuit that is hot all the time. Ground (yellow) refers to that part of the circuit that is ground all the time. These are the easy ones!

Now look at the second circuit in

Mastering Complex Wiring Diagrams

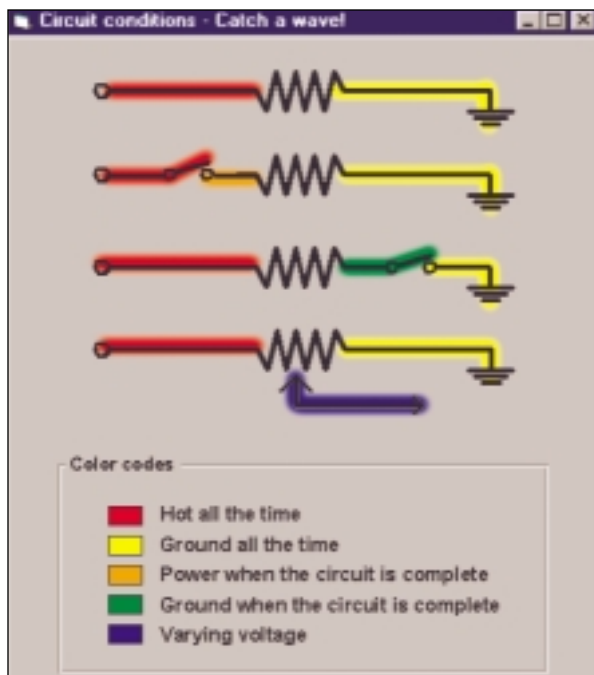

Fig. 1. These colors represent the basic voltage conditions that exist in most circuits. Using markers to color-code different circuit conditions, as shown here, makes dealing with complex diagrams easier.

Fig. 1. Notice the unique condition between the switch and the load. The orange color identifies it as power when the circuit is complete. This means that when the switch is closed (completing the circuit), it serves as a direct path to the power source. Your meter will display source voltage. When the switch is open, it will read zero volts.

But is that ground? No, because of the resistance of the load, which is between the test point and ground!

The next circuit shows a condition that is ground when the circuit is complete (green). In this instance, the switch serves as a direct path to ground. Testing between the load and the switch when the circuit is complete will display zero volts on your meter. Open the switch and it will read source voltage. Again, because of the load between our test point and the power supply, it does not fit into the “power” category.

The final condition is a varying voltage (blue). This is a signal that changes voltage levels in a linear fashion. A throttle position sensor is a classic example of a device that does just that.

le position sensor is a classic example of a device that does just that.

A Diagnostic Starting Point

Comprehending these five basic conditions is certainly a good starting point for diagnosis, but there are many variations. Getting further into the dynamics of circuits is a matter of

understanding the behavior of electricity and how components affect it. This might sound complicated, but it’s really not.

Just as we have manuals for particular vehicles, we need manuals for electricity and basic circuit componentry. When it comes to books and reference material, my motto is, you don’t have to know everything, just where to find it when you need it and how to understand it enough to apply it. One of my favorite manuals is *Getting Started in Electronics* by Forrest Mimms (available at most Radio Shack stores). I also have an extensive book collection, and certainly use the library when necessary.

Coloring wiring diagrams goes far beyond the examples in Fig. 1. I color them on a regular basis, especially when I’m in a situation that involves dealing with complex circuits. I simply copy the diagram, make a color legend and color it using highlight markers. This saves time because it forces me to analyze the diagram, the colors give me a quick reference for testing and it divides the most complex diagrams into manageable building blocks.

The diagram on the left in Fig. 2 below, a vacuum switching valve (VSV) system for idle control, is from a Toyota service manual. Coloring it (right) shows that there are four basic conditions in this system. Once you have a diagram colored, applying what you see is easy. Using Fig. 2 as an example,

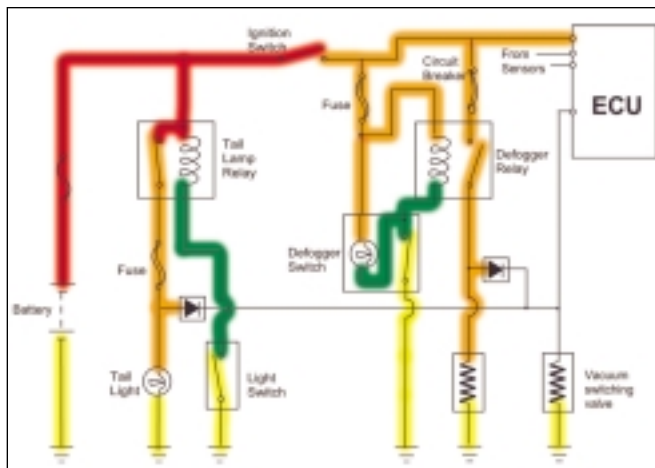
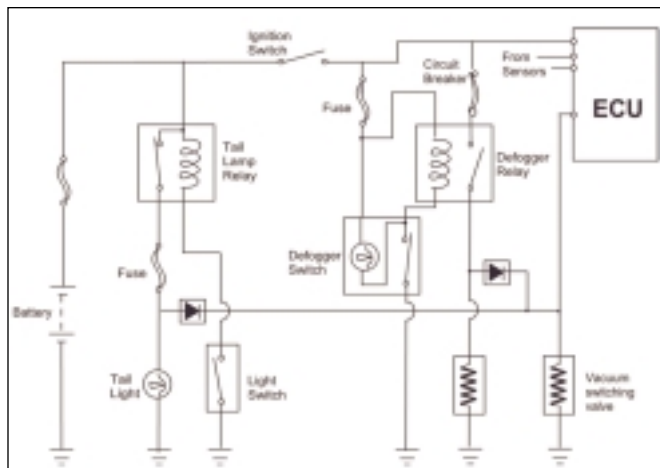

Fig. 2. The diagram on the left is from a Toyota service manual. It shows all the circuits related to the vacuum switching valve (VSV) used to speed up the idle under certain conditions. Color-coding the diagram (as shown at right) divides it into manageable bits. The colors also act as a quick reference for expected test results.

Mastering Complex Wiring Diagrams

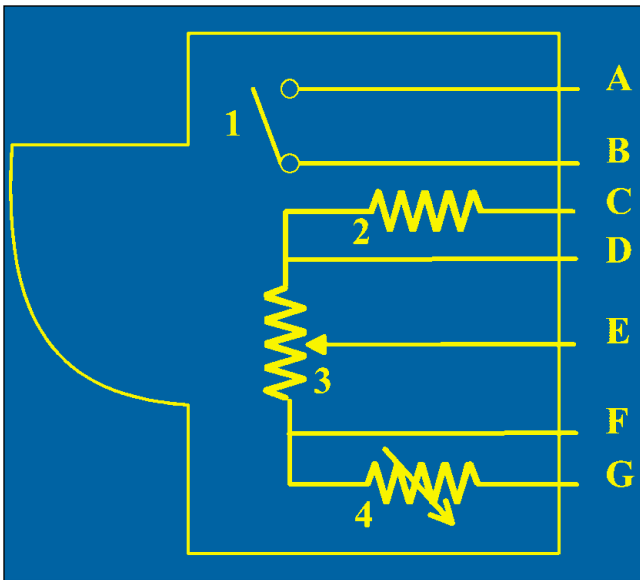

Fig. 3. There's enough information in this airflow meter diagram to know exactly what to expect from each of these pin-outs. The key is to take the right approach.

if you were to test between the defogger switch and relay and read source voltage, what does this mean? Instead of reanalyzing the diagram, we simply reference the color code to the legend. Green equals ground when the circuit is complete, right? Since the meter reads source voltage, the circuit must be open between the test point and the ground. Perhaps the switch is open.

Close inspection of the diagram on the right in Fig. 2 shows that the wire between the ECU and VSV is not colored. What color should it be? Well, one of our rules is that there has to be a power and ground to every load. Since one side of the switch is already connected to ground, the other wire must be one of the power conditions, red or orange. But which one? Well, we know the ECU controls the VSV, and since the VSV is not on all the time, the ECU must act as a switch. Color this wire orange.

Referencing Fig. 1, you see that the only circuit that represents the VSV is the second one—power to switch, load and then to ground! Okay, we know the ECU turns the VSV on and off, but what about the wires that connect it to the other circuits in this system? And what are the square boxes with the triangles in them? Since the wires to them

quite get what's going on, what else can you do? Read the description of the system given in the service manual. The manual tells us that the VSV is located under the intake manifold. In order to control the speed at which the engine idles, it increases or decreases (based on signals from the ECU, the taillamp and the defogger relay) the amount of air allowed to bypass the throttle valve. The ECU sends signals to the VSV, in accordance with signals from various sensors, to cause the engine to idle at the appropriate speed.

Now a picture is developing. The system description basically tells us that the VSV can be turned on by any of three circuits. And we know from the wiring diagram that the three circuits mentioned should not turn each other on. For example, the taillight circuit

from the VSV are directly connected, they must be the condition orange also, but what are those symbols? Get out your reference manual and you'll find that they're diodes. What do diodes do? They're one-way electrical valves that, among other things, offer spike protection, AC rectification and logic. At this point, you should have more than enough information to understand the complete logic of this system.

If you still can't

can turn on the VSV, but not the defogger. The defogger should also be able to turn on the VSV, but not the taillights. The diodes must be used to control this logic. Their one-way valve action allows for all three circuits to be tied to the VSV without affecting one another.

Some wiring diagrams offer more detail than others. Those that do not offer much—especially the ones with integrated circuits and controllers—can be very tough to deal with even when you have a system description. For example, there are times when you need to know when and under what conditions an action in a circuit is supposed to take place. Every now and then the answer can be determined by deciphering the diagnostics in the manual.

Do Some Investigating

Sometimes the key to understanding involves a little detective work, like I did with my first "bad" airflow meter. Once I determined that it was bad, I pried the cap off to expose the internal circuits. By reading the component description in the manual and examining the wiring diagram, I was able to make the connection among the physical part, the description in the manual and the diagram. I could even see the problem area, which was related to

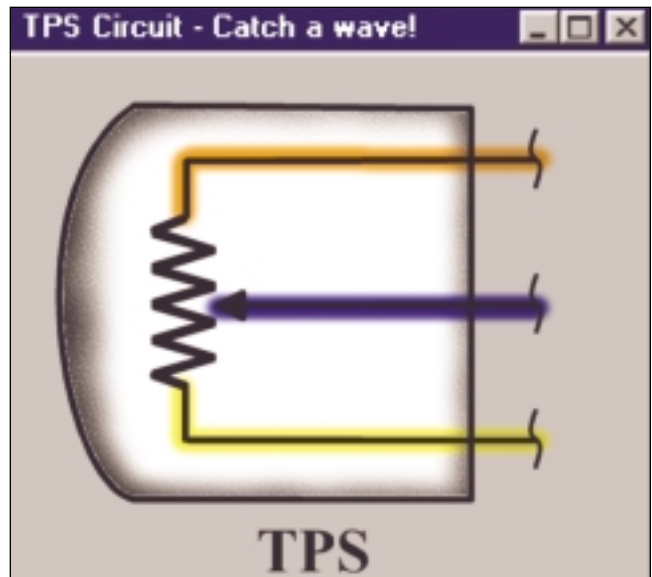

Fig. 4. A throttle position sensor (TPS) is nothing more than a simple potentiometer. It usually has three wires—power, signal and ground, which supplies a varying voltage.

Mastering Complex Wiring Diagrams

the skewed output signal that condemned the meter!

Fig. 3 on page 34 is the internal diagram for an airflow meter. This one is rather simple but at the same time has much to offer. There's enough information in this diagram for you to know what signals to expect from every pin (A-G). As you examine this diagram, keep in mind that the same rules mentioned in the beginning of the article apply, and so do the voltage conditions listed in Fig. 1.

The first step is to identify the components in the diagram. If you look these up in an electronics reference manual, you'd find that there are three types of resistors and one switch. Don't confuse the switch and resistor symbols for a relay. A relay contains a coil whose symbol is a series of loops, as opposed to the sawtooth appearance of the resistor.

No. 1 in the diagram represents a simple switch. We stated earlier that every circuit has a load. Therefore, this switch switches the unseen load either to ground or power. Anyone who has played with a hooked-up airflow meter with key on/engine off knows that as soon as you move the vane open, the fuel pump turns on. Must be what this switch is for. But would you expect the fuel pump to be run directly from this switch? Nah, that would be a lot of current to handle. Most likely this switch completes the circuit for a low-current relay, which then activates the pump. So the conditions of A and B are either red and orange or green and yellow.

No. 2 is a fixed resistor and No. 3 is a potentiometer just like a TPS. If you looked inside an airflow meter you could see the potentiometer and the fact that it moves with the vane. The signal from this device would be a varying voltage, which is one of our basic conditions. No. 4 turns out to be a temperature-sensitive resistor similar to a coolant temperature sensor. In this case, it must be used to measure the temperature of the incoming air. It also outputs a varying voltage.

If you understand the principles of coolant temperature sensors and TPSs, you probably already have enough information to answer the questions of

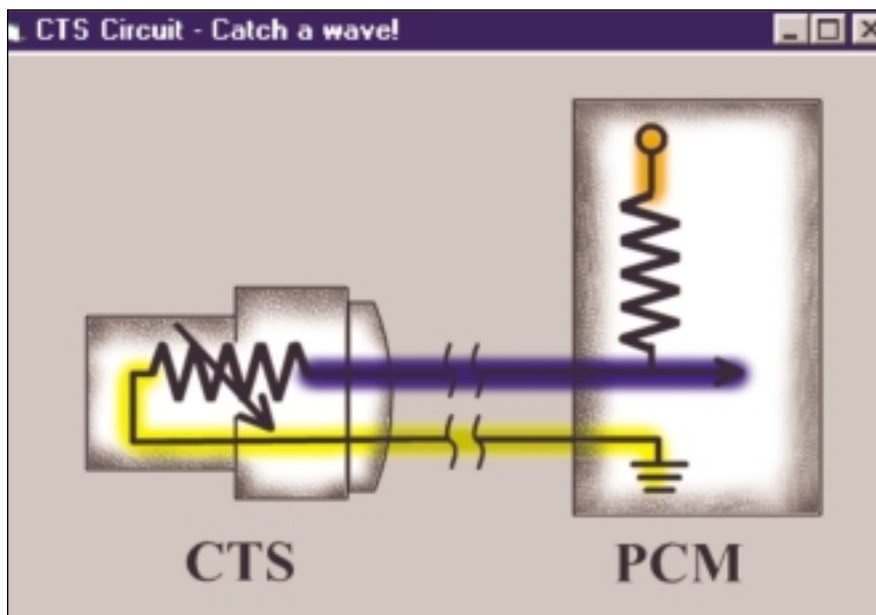

Fig. 5. A coolant temperature sensor (CTS) circuit is actually two resistors set up in series. The resistor in the computer is often called a pull-up resistor.

what to expect at every pin of this airflow meter, what type of signal you'd see and how to adjust your meter.

Confused? Let's look at these components separately and then tie everything together. How many wires go to a TPS? Three (Fig. 4, page 34). How many go to a standard CTS? Two (Fig. 5, above). Remember the rule: Every circuit has to have a power and a ground. Therefore, the three wires of the TPS have to be power, signal and ground. The two wires of the coolant temperature sensor have to be signal and ground. (The power source of a two-wire coolant sensor is in the originating controller.) What do these two sensors have in common? Grounds! Now, let's go back to Fig. 3. F has to be a ground. G has to be the signal from the temperature sensor. E, due to the arrow, is the signal for the vane's potentiometer. D is a voltage used by the computer as a reference point for the measurements of the potentiometer. C is the power for the potentiometer.

If you wish to continue with these types of exercises, the next step would be to find diagrams that include transistors. And don't limit yourself to automotive schematics, either. The book *Getting Started in Electronics* includes many simple circuits that you

can decipher and build! You might also want to expand on the color codes legend. For example, many digital components, such as Hall sensors, are very repetitive. Most Hall sensors are simple switches to ground; therefore, it would make sense to ID them using a dashed green line. An AC sensor, such as a wheel speed sensor, might be a dashed blue line.

The Bottom Line

Wiring diagrams are a key piece of the diagnostic picture, and I can't stress enough the importance of mastering them. Understanding diagrams means understanding electricity, which leads to understanding the information your test equipment offers. This is paramount for our success today and in the future.

Remember, being an automotive technician means being an investigator. Use those investigative skills to build a solid foundation, a foundation based on understanding, knowledge and insight. Go for it! **M**

For a free copy of this article, write to: Fulfillment Dept., MOTOR Magazine, 5600 Crooks Rd., Troy, MI 48098. Additional copies are \$2 each. Send check or money order.